



## **ZEISS Axiolab 5**

Optimize Clinical and Biomedical Lab Efficiency with Smart Microscopy

[zeiss.com/axiolab](https://zeiss.com/axiolab)



Seeing beyond

# Optimize Clinical and Biomedical Lab Efficiency with Smart Microscopy

- › In Brief
- › **The Advantages**
- › The Applications
- › The System
- › Technology and Details
- › Service

Axiolab 5 meets the rigorous demands of clinical and biomedical laboratories. Its compact and ergonomic design not only saves space but also ensures easy handling, catering to the high-paced environment where efficiency and comfort are paramount.

The microscope is designed with your convenience in mind, enabling you to sit comfortably and maintain a relaxed posture during long hours of microscope work. With adjustable features, you can customize your microscope to suit your individual preferences, ensuring an optimal fit and reducing the risk of discomfort or strain.

Partner Axiolab 5 with the Axiocam 208 color microscope camera to fully leverage the smart microscopy concept, offering a revolutionary approach to digital documentation. Simply focus on your sample and press a single button to capture sharp, true-color images that mirror the view through the eyepieces, with all details and subtle color variations clearly visible.

With Axiolab 5, you simplify digital documentation in your clinical and biomedical lab, experiencing the perfect blend of ergonomic design and speed tailored to your specific needs.



# Simpler. More Intelligent. More Integrated.

- › In Brief
- › **The Advantages**
- › The Applications
- › The System
- › Technology and Details
- › Service

## Increase Efficiency with Smart Microscopy

Once you find a region of interest, simply press the snap button right on the stand to acquire the image. It's as easy as that. You can control the microscope and its attached camera without even changing your grip. Your smart microscope system then automatically adjusts the parameters for you and documents your sample precisely as you see it through the eyepieces – rich in detail and in true color. The correct scaling is included automatically. Furthermore, Axiolab 5 with smart microscopy does not necessarily require a computer and extra software. You can save lab space and costs. You work more efficiently with high data accuracy and always stay focused on your sample.



## Work Comfortably with Adaptable Ergonomics

Axiolab 5 is strong on ergonomics and efficiency. You can access all main controls with just one hand, including the snap button, stage drive, focus adjustment, and brightness control. ZEISS ergotubes and the height and torque adaptable stage handle allow you to work in a comfortable position. The dual specimen holder means fewer slide changes – for example, when you're examining IHC slides – so fatigue is reduced. The new light manager provides uniform brightness at all magnifications, eliminating manual lamp intensity adjustments when changing objectives. Overall, Axiolab 5 streamlines and simplifies manual steps, enabling you to work for longer periods with enhanced efficiency and greater comfort.



## More Economic and Reliable

Axiolab 5 is on your side when it comes to cost- and energy-saving. Activate ECO mode, for instance, and Axiolab 5 automatically goes to standby after being idle for 15 minutes. This saves energy and extends illumination life time. In transmitted light, the powerful white LED allows you to visualize your sample in natural colors. Even subtle color differences can be clearly seen.

For fluorescence, the integrated LEDs in various wavelengths are easier and safer to use than e.g. classical mercury lamps. With LEDs, you avoid warm-up and cool-down times. Lamp replacement and lamp adjustment is a thing of the past.



# Expand Your Possibilities

- › In Brief
- › **The Advantages**
- › The Applications
- › The System
- › Technology and Details
- › Service

## Boost your Efficiency – with Smart Microscopy

Efficiency and quality are key in your lab, but it can take a lot of time to acquire detail-rich, true-color images. You know the drill: place the sample, focus your region of interest, switch to the computer, adjust settings such as white balance, exposure time and gain, then acquire an image, insert a scale bar, switch back to the microscope ... and so on. That's what a typical documentation workflow looks like.

Now, with Axiolab 5, you can stay focused on your sample at all times, thanks to smart microscopy. Digital documentation is inherent in the system design. Just press the ergonomic snap button on the microscope and you're done. The procedure integrates perfectly with your established microscopy workflow and boosts your efficiency tremendously.

### Routine imaging workflow



Smart functionality for digital documentation in brightfield and fluorescence for routine applications.

### Efficiency gain:

Eyes and hands stay on the microscope.



# Expand Your Possibilities

- › In Brief
- › **The Advantages**
- › The Applications
- › The System
- › Technology and Details
- › Service

## This is Smart Microscopy – Digital Documentation Made Easy

In combination with the microscope cameras Axiocam 202 mono or Axiocam 208 color, you have the full advantage of a smart stand-alone microscope solution.

Camera settings such as white balance, exposure time, and image enhancement functions are done automatically. Without needing additional imaging software or even a computer, you can:

- Snap images and record videos directly from your stand
- Use mouse, and optionally keyboard, to control your camera via OSD (on screen display)
- Save settings
- Store images with all metadata of the microscope and camera as well as scaling information
- Predefine the name or rename your image

### Stand-alone for Basic Routine Imaging



ZEISS Axiolab 5 operates independently of a computer system.

### ZEISS Labscope for Advanced Routine Imaging



Operating ZEISS Axiolab 5 with ZEISS Labscope imaging software is ideal for easy documentation with annotation and sharing possibilities.

### ZEISS ZEN for Research Applications

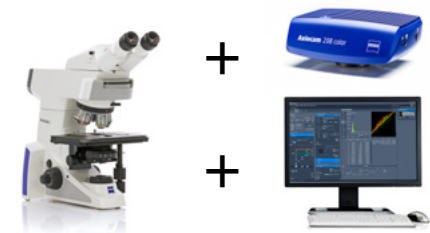

Use ZEN imaging software to perform advanced imaging tasks with ZEISS Axiolab 5.

# Expand Your Possibilities

- › In Brief
- › **The Advantages**
- › The Applications
- › The System
- › Technology and Details
- › Service

## Stay Relaxed and Protect Your Health

In your clinical or biomedical lab you quickly evaluate the status of tissue to decide on further treatment. You regularly check a huge amount of tissue slides under time pressure. Speed is essential. This work can be tiresome as you sit the whole day in front of your microscope. Therefore, a comfortable and relaxed sitting position is key. All microscope controls need to be ergonomic and comfortable. And fit perfectly to your person.

- Use adaptable ergophototubes to maintain an upright body posture.
- Adjust the height of the stage drive to let your hands rest comfortably on the table. Fine-tune the stage friction control for smoother movements with minimal effort.
- With ergonomically positioned snap buttons you acquire images and videos directly from the stand.

- Use the ECO mode and your microscope goes to standby after being idle for 15 minutes. This saves energy and extends the lifetime of the illumination.
- The active light manager memorizes the individually set light intensity per objective. You profit from uniform brightness at all magnifications and reduced eye fatigue.
- With a field of view of 25 mm you see a >20 % larger area compared to conventional 22 mm.
- With the 10 W LED you visualize and document your samples in natural colors where even subtle color differences are clearly visible.

## Choose between two ergotubes:



Ergophototube with 23 mm FOV and a tilting range from  $-2$  to  $+28^\circ$



Ergophototube with 25 mm FOV and a tilting range from  $-2$  to  $+28^\circ$ . Also suitable for co-observation setups.

## How to Adjust Your Microscope for Ergonomic Use



[Click here to view this video](#)

# Expand Your Possibilities

- › In Brief
- › **The Advantages**
- › The Applications
- › The System
- › Technology and Details
- › Service

## Collaborate, Discuss, Share: Co-observation Systems for Simultaneous Use by Multiple Viewers

Multidiscussion or co-observation systems are indispensable tools for lab training, consultation and education. Imagine you have an interesting structure in your pathological sample, where you need a second opinion or advice. Or you educate your students on different types of blood cells where you need to see the same image simultaneously. Experience a new way of flexibility with the active two-position co-observation unit, available with your Axiolab 5. It allows you to arrange your setup in either a front-to-back or

side-by-side configuration (left or right), providing a space-saving solution that adapts to your specific room or table requirements. The homogeneously illuminated field of view and the consistent image brightness for main and co-observer ensures optimal visibility and a comfortable and productive workplace environment. The system is equipped with a light pointer that allows you to highlight interesting details in the specimen. Choose from a range of colors, including white, blue, green, and red. For larger multi-discussion

solutions ZEISS provides various setup options for up to 20 co-observers. All your colleagues or students can enjoy a consistent viewing experience, seeing images in the same orientation and brightness as you. This eliminates any potential irritation caused by rotated or mirrored images. In addition, each observation tube is equipped with its own support and height adjustment feature, which guarantees a stable and robust setup.

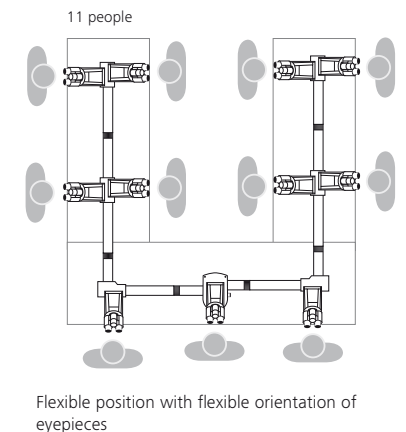
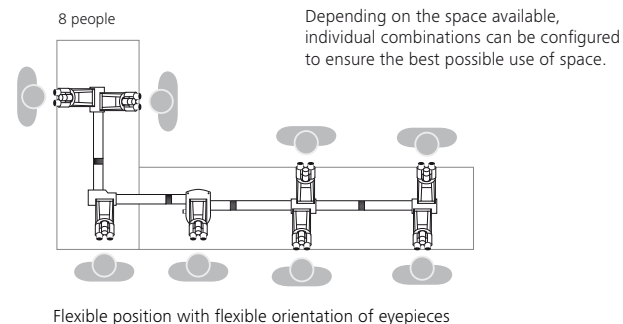
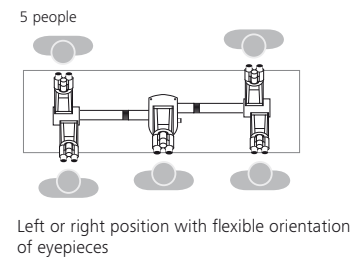
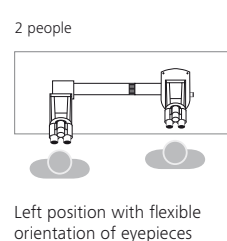
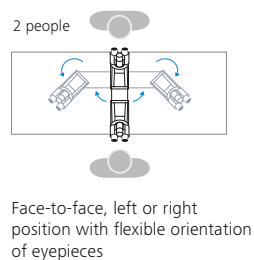



## Expand Your Possibilities

- › In Brief
- › **The Advantages**
- › The Applications
- › The System
- › Technology and Details
- › Service

Fluorescence microscopy requires an intense light source that will excite fluorescent dyes and proteins. Axiolab 5 FL is equipped with long lifetime, service- and adjustment-free and energy saving LED illumination, which allows for up to 3-channel fluorescence documentation. Each LED intensity can be controlled individually. Thanks to its encoding, Axiolab 5 recognizes which LED is currently in use and adjusts the light intensity to the last setting used.

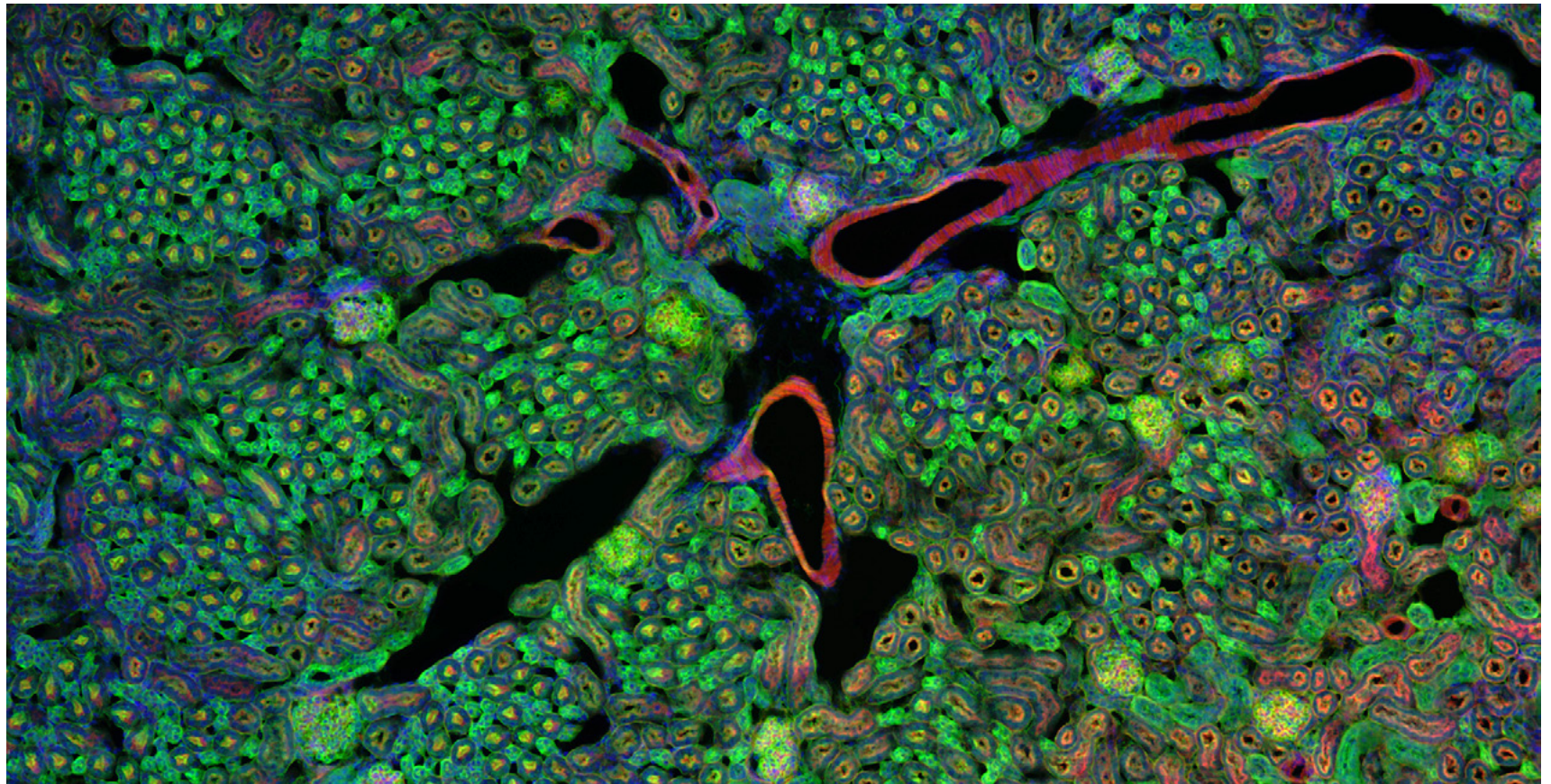

▶ [Click here to view this video](#)



# Tailored Precisely to Your Applications

- .....
- › In Brief
- .....
- › The Advantages
- .....
- › **The Applications**
- .....
- › The System
- .....
- › Technology and Details
- .....
- › Service
- .....

Field of Application	Histopathology	Cytology	Hematology	Microbiology	Cytogenetics	Food & Agriculture	Andrology & Gynecology
<b>General task</b>	Examination of tissue samples for diseases or abnormalities	Evaluation of structure, composition and growth of single cells and cell structures	Examination of blood samples (EDTA blood) and bone marrow for quantity, shape, condition of blood cells	Study of pathogenic microorganisms that cause infectious disease	Study of chromosomal abnormalities in relation to cell behaviour /disease; molecular cytogenetic investigations	Examination of quality of food or beverage production; analyzing the nutritional content	Evaluation of sperm concentration, motility / vitality and sperm morphology; screen gynecological smears for cytological and microbiological findings
<b>Typical samples</b>	Histological tissue from e.g. organs such as lung or kidney	Pap smears; body fluids like urine, sputum, and pleural fluid; fine needle aspirations e.g. from lung	Blood smears, bone marrow smears	Bacteria, virus, fungi, parasites	Blood smears, bone marrow smears, cytopins, tissue samples	Beer, wine, cheese, meat, crop, soy, starch	Gynecological smears, semen
<b>Common stainings/ preparations</b>	Hematoxylin and Eosin (H&E) staining, Immunohistochemistry, frozen sections, formalin fixed and paraffin embedded sections	Papanicolaou (PAP), Azur-Eosin-Methylenblue, Giemsa, Immunohistochemistry, FISH	Giemsa, Pappenheim, immunohistochemistry (IHC)	Gram stain, acidic-fast stain, methylene blue, Ziehl-Neelsen, immunofluorescence	Giemsa (G-banding), quinacrine and other banding stains, FISH	Native; gram staining; sections	Papanicolaou, Eosine-nigrosine, SPERMAC, immuno-fluorescence
<b>Typical contrasting techniques</b>	Brightfield, simple polarization	Brightfield, phase contrast	Brightfield, darkfield, phase contrast, fluorescence	Brightfield, darkfield, phase contrast, fluorescence	Brightfield, fluorescence	Brightfield, darkfield, phase contrast, polarization	Brightfield, phase contrast, fluorescence

# ZEISS Axiolab 5 at Work

- › In Brief
- › The Advantages
- › **The Applications**
- › The System
- › Technology and Details
- › Service

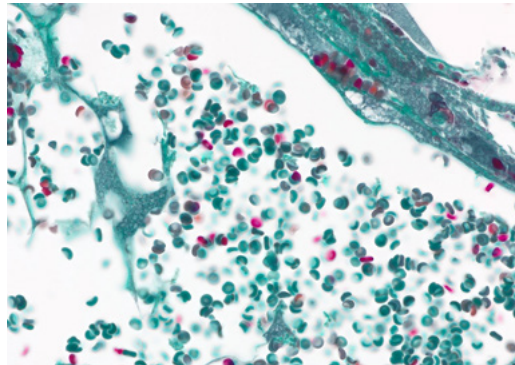

*Blood vessels, transmitted light brightfield, objective: Plan-Apochromat 40x/1.4*

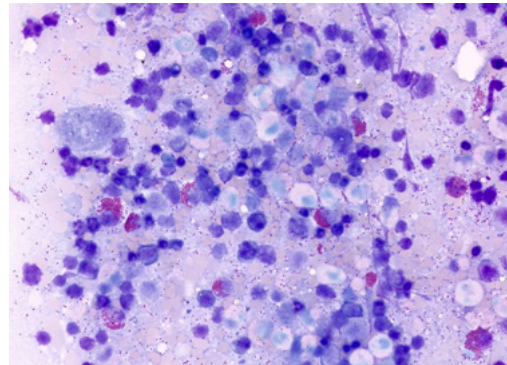

*Red bone marrow, transmitted light brightfield, objective: Plan-Apochromat 40x/1.4*

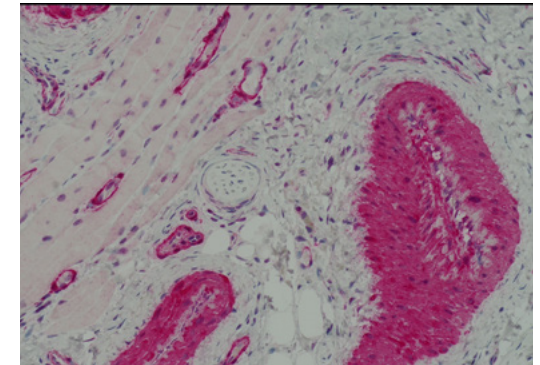

*Skin, HE staining, transmitted light brightfield, objective: EC Plan-NEOFLUAR 20x, sample courtesy of Dr. G. Metzler, University Hospital Tübingen, Germany*

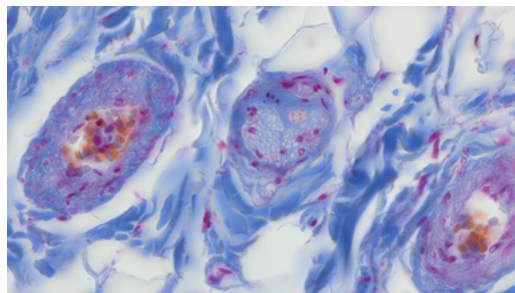

*Peripheral nerve, cross section, transmitted light brightfield, objective: Plan-Apochromat 40x/1.4 oil*

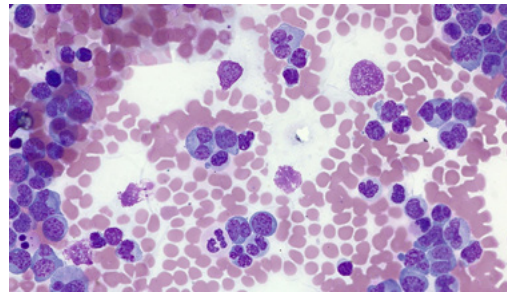

*Representative image of Leukemia in human blood, transmitted light brightfield, Giemsa staining, objective: Plan-Apochromat 40x/1.4 oil*

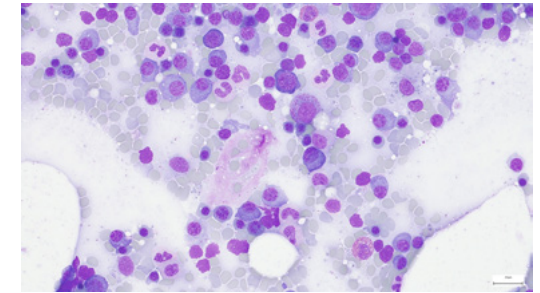

*Bone marrow, transmitted light brightfield, 40x objective*

# Your Flexible Choice of Components

- › In Brief
- › The Advantages
- › The Applications
- › **The System**
- › Technology and Details
- › Service



## 1 Microscope

ZEISS Axiolab 5:

- Encoded stand with transmitted light
- Encoded stand with transmitted light and reflected light fluorescence

## 2 Objectives

Recommended classes of objectives:

- A-Plan
- N-Achroplan
- EC Plan-NEOFLUAR

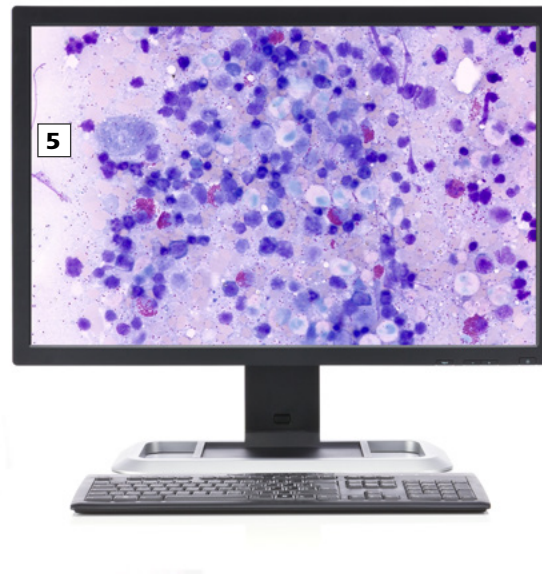

## 3 Illumination

Transmitted light:

- 10 W LED illumination
- 35 W halogen illumination (optional)

Reflected light:

- Up to three fluorescence LEDs

## 4 Cameras

Recommended cameras:

- ZEISS Axiocam 208 color  
(with Axiolab 5 encoded transmitted light stand)
- ZEISS Axiocam 202 mono  
(with Axiolab 5 encoded fluorescence stand)



## 5 Software

- Stand-alone (on screen display)
- Labscope imaging software
- ZEN imaging software

## 6 Accessories

- Ergophototube with 23 mm FOV
- Ergophototube with 25 mm FOV
- Dual-observation and multidiscussion units

# System Overview

- » In Brief
- » The Advantages
- » The Applications
- » The System
- » Technology and Details
- » Service

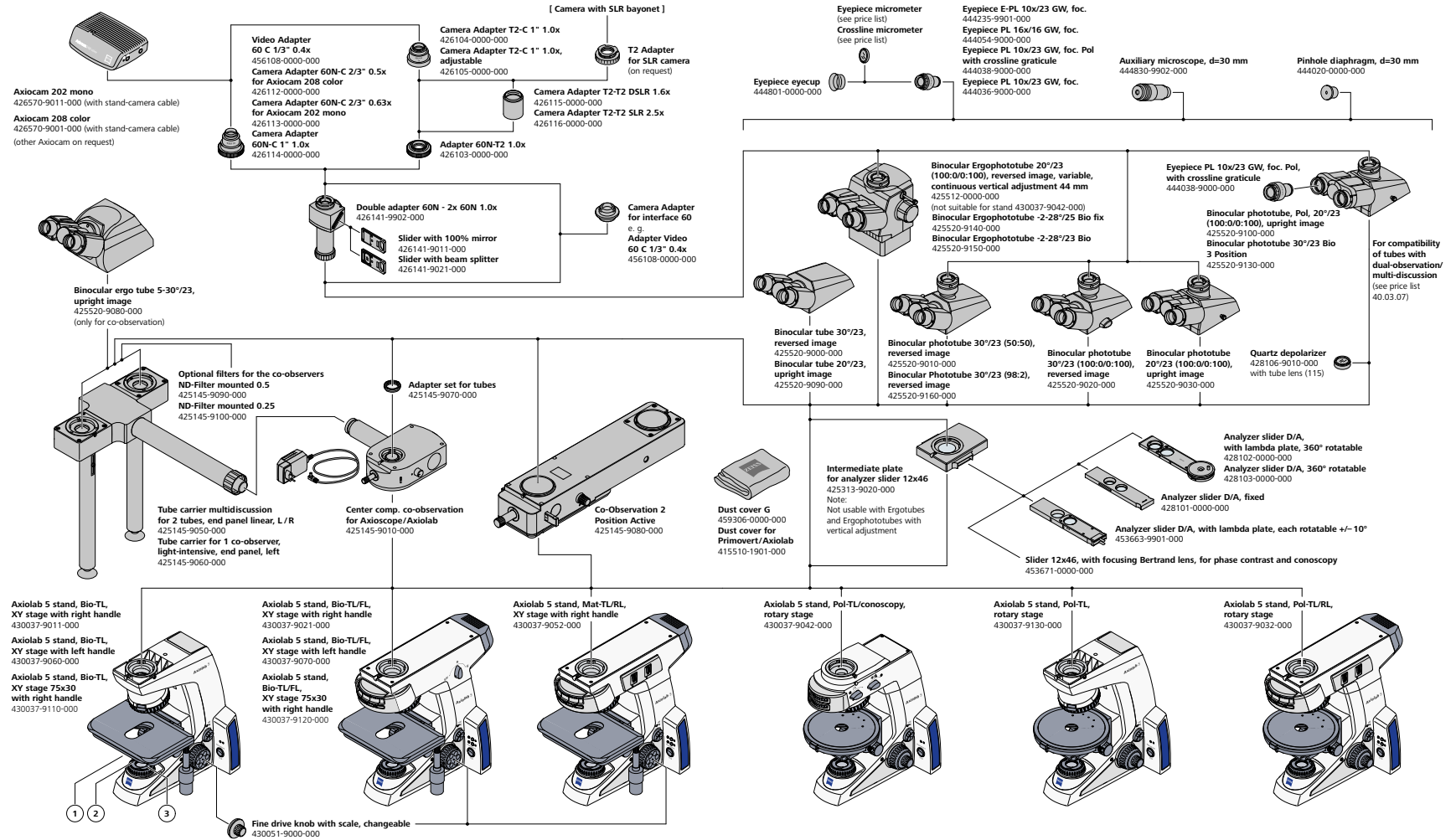

# System Overview

- › In Brief
- › The Advantages
- › The Applications
- › **The System**
- › Technology and Details
- › Service

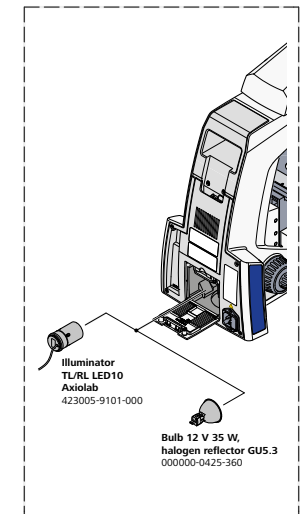
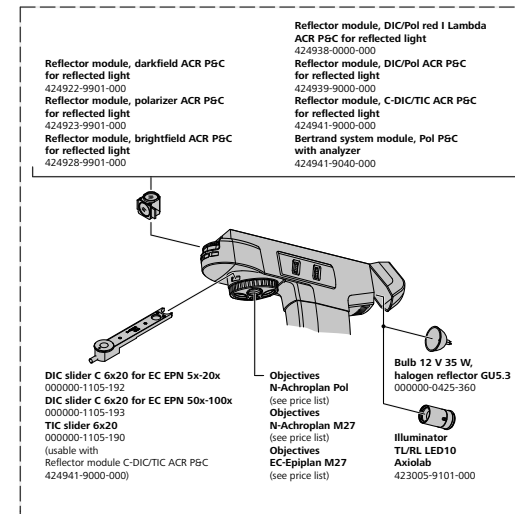
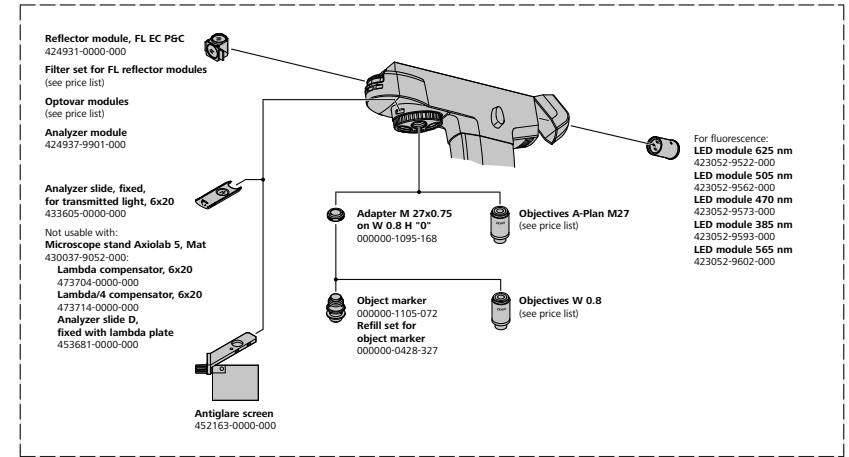
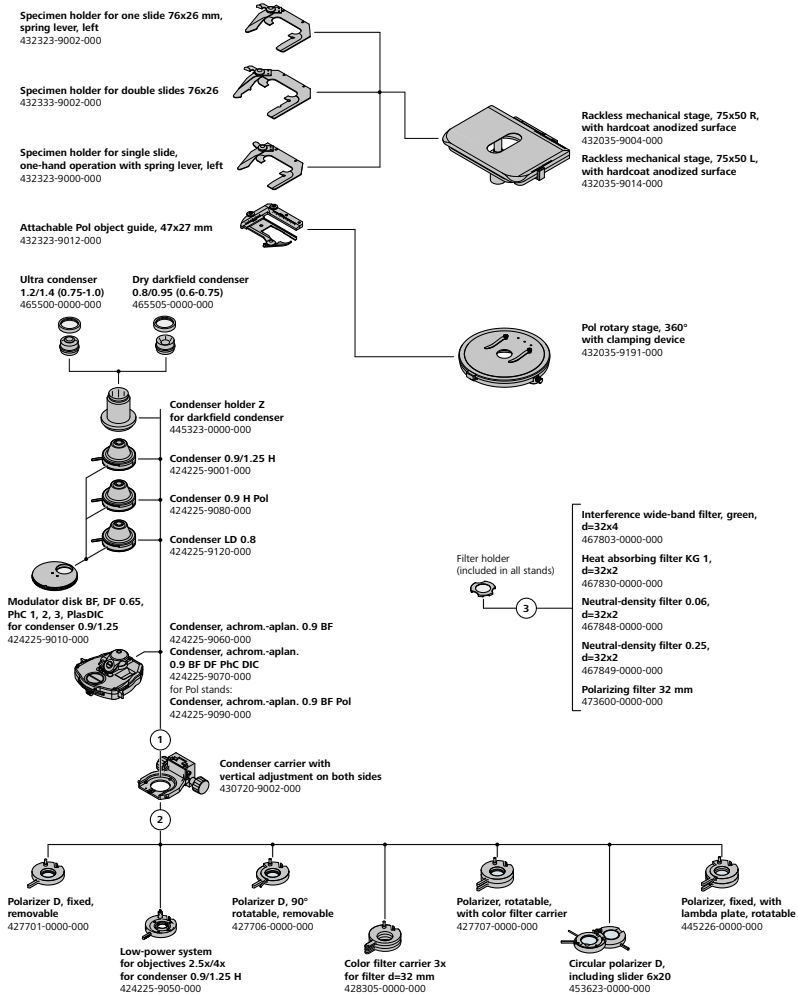



# Technical Specifications

- › In Brief
- › The Advantages
- › The Applications
- › The System
- › **Technology and Details**
- › Service

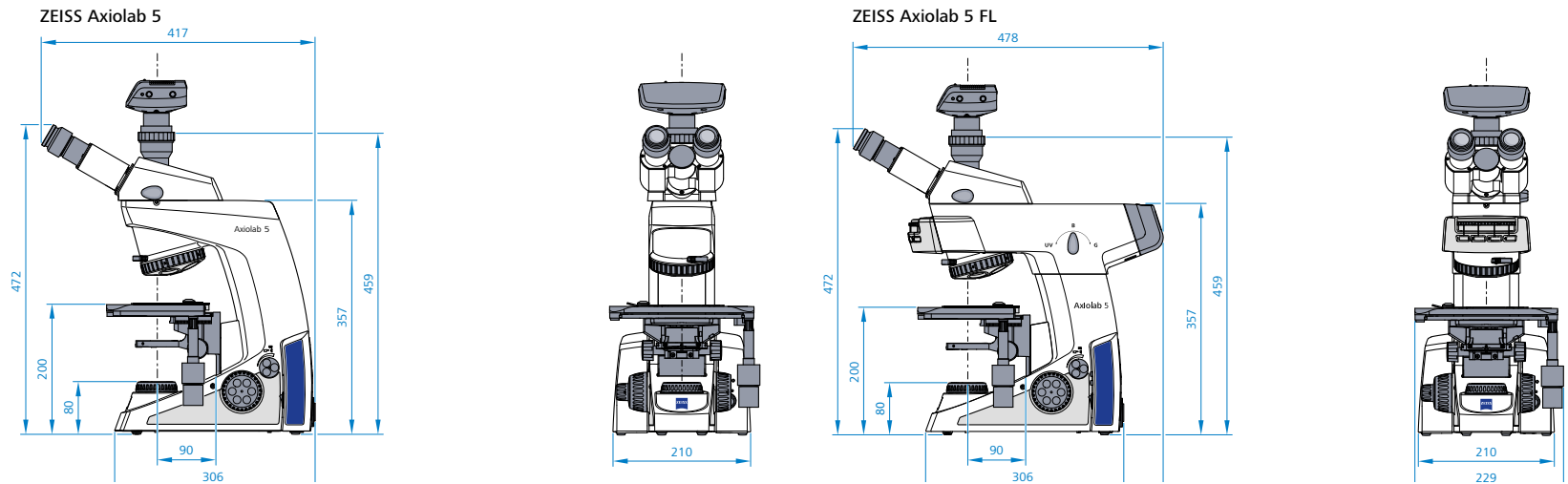

## Dimensions (length x width x height)

Axiolab 5 basic microscope stand  
without tube (430037-9011-000)

Approx. 304 mm x 210 mm x 357.5 mm

The other stand types differ slightly in depth and significantly in height, depending on the tube used.

## Operation

Permissible ambient temperature	+10 °C to +40 °C
Permissible relative humidity (without condensation)	Max. 75 % at 35 °C
Highest permitted altitude of use	2,000 m
Air pressure	800 hPa to 1,060 hPa
Degree of pollution	2

# Technical Specifications

- › In Brief
- › The Advantages
- › The Applications
- › The System
- › **Technology and Details**
- › Service

		ZEISS Axiolab 5 TL	ZEISS Axiolab 5 TL+FL
<b>Transmitted light illumination</b>	Material number	430037-9011-000	430037-9021-000
	TL light source	LED 10W, >60.000h life time Optional Hal 35W	LED 10W, >60.000h life time Optional Hal 35W
	TL filter holder	●	●
<b>Fluorescence/reflected light illumination</b>	FL/RL light source	NA	FL LED modules
	Independent intensity control on stand of each FL-LED	NA	●
	FL-LED intensity memory function	NA	●
	Automatic mechanical shutter in TL for fluorescence imaging	NA	●
	Reflector turret	NA	4-position, encoded
	RL/TL switch buttons	NA	●
<b>Observation and documentation</b>	Eco mode	●	●
	Light intensity manager	●	● (TL & FL)
	Snap button to take images and videos on stand	●	●
	Contrasting methods	BF, DF, Ph and simple TL Pol	BF, DF, Ph, FL and simple TL Pol
	Field of view	25 mm	25 mm
	Optical system	Infinite, IC <sup>2</sup> S	Infinite, IC <sup>2</sup> S
	Camera tube	●	●
	Full Köhler	●	●
	Ergophototube	●	●
<b>Stand</b>	Nosepiece	5X H, encoded, M27	5X H, encoded, M27
	Stage	Mechanical stage 75×50 (rackless with hardcoat anodized surface, right or left drive, extendable and with torque adjustment)	Mechanical stage 75×50 (rackless with hardcoat anodized surface, right or left drive, extendable and with torque adjustment)
	Z Focus range	15 mm	15 mm
	Focus knob	Fine drive knob left and fine drive disk right	Fine drive knob left and fine drive disk right
	Specimen holder	Dual slide holder for one-hand operation, spring lever left Optional: holder for single slide	Dual slide holder for one-hand operation, spring lever left Optional: holder for single slide
	Eyepiece, diopter adjustment	Up to ± 5 diopter	Up to ± 5 diopter
	Integrated carrying handle	●	●
	Integrated solution to accommodate cable when stored	●	●
	Integrated solution to accommodate tools (allen wrench) when stored	●	●
	Power unit	Integrated	Integrated

# Technical Specifications

- › In Brief
- › The Advantages
- › The Applications
- › The System
- › **Technology and Details**
- › Service

Tube specifications	Viewing angle	Adjustment	Viewing height* in mm
Binocular phototube 30° / 23 (50:50)	30°	–	449 / 485
Binocular phototube 30° / 23 (100:100)	30°	–	449 / 485
Binocular ergotube 15° / 23 (50 / 50), telescopic, height, upright image	15°	Height, telescopic	410 / 509
Binocular ergotube 20° / 23 (100 / 100), reversed image, 44 mm height	20°	Height	457 / 574
Binocular ergophototube –2° to 28° / 23 (50:50)	–2° to 28°	Inclination	356 / 507
Binocular ergophototube –2° to 28° / 25 (50:50)	–2° to 28°	Inclination	392 / 537

\* Range between the lower and upper setting of the eyepieces, e.g. 442 / 481 → 442 mm to 481 mm



# ZEISS Service – Your Partner at All Times

Your microscope system from ZEISS is one of your most important tools. For over 175 years, the ZEISS brand and our experience have stood for reliable equipment with a long life in the field of microscopy. You can count on superior service and support - before and after installation. Our skilled ZEISS service team makes sure that your microscope is always ready for use.

- › In Brief
- › The Advantages
- › The Applications
- › The System
- › Technology and Details
- › **Service**

## Procurement

- Lab Planning & Construction Site Management
- Site Inspection & Environmental Analysis
- GMP-Qualification IQ/OQ
- Installation & Handover
- IT Integration Support
- Startup Training

## Operation

- Predictive Service Remote Monitoring
- Inspection & Preventive Maintenance
  - Software Maintenance Agreements
    - Operation & Application Training
    - Expert Phone & Remote Support
  - Protect Service Agreements
    - Metrological Calibration
    - Instrument Relocation
      - Consumables
      - Repairs

## New Investment

- Decommissioning
- Trade In

## Retrofit

- Customized Engineering
- Upgrades & Modernization
- Customized Workflows via ZEISS arivis Cloud



Please note: Availability of services depends on product line and location



**Carl Zeiss Microscopy GmbH**  
07745 Jena, Germany  
microscopy@zeiss.com  
[www.zeiss.com/axiolab](http://www.zeiss.com/axiolab)

**Follow us on social media:**

