

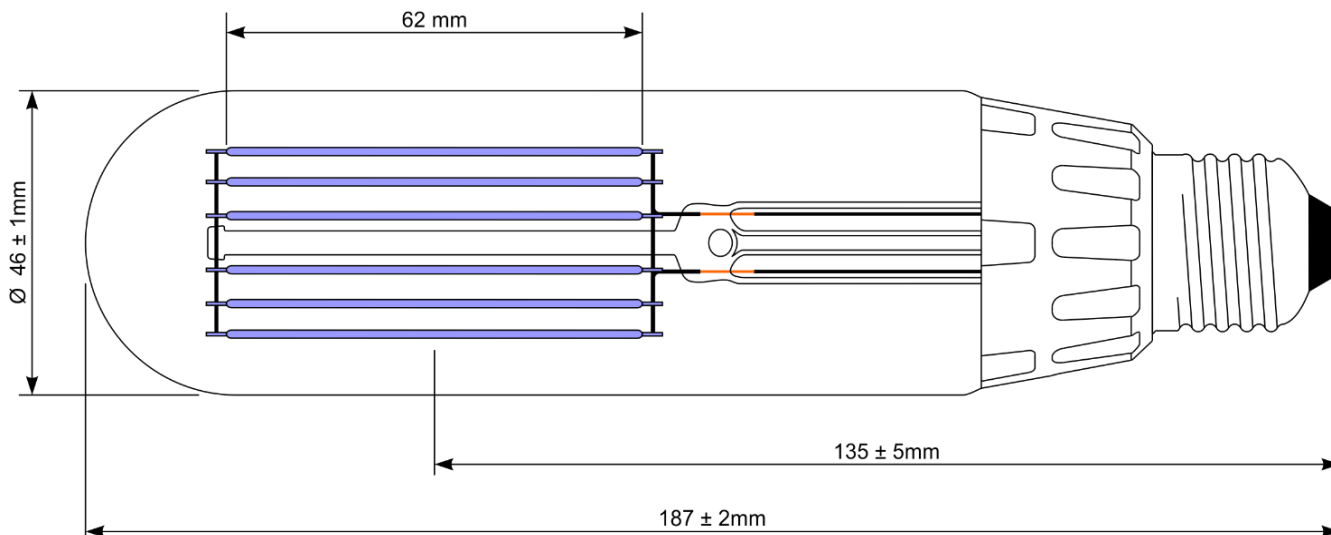

MECHANICAL DATA:



Bulb type : T46

Cap type : E14/24x17

Finish: Clear hardglass bulb, UV-resistant ceramic base

ELECTRICAL DATA:

		RATED	MIN.	MAX.
Lamp Power	(W) :	5.0	4.5	5.5
Lamp Voltage	(V) :	230	220	240
Lamp Current	(mA) :	45	41	50
Energy Consumption per 1000h	(kW/h) :	5.0	-	-
Power Factor	(λ) :	0.5	-	-
Supply Frequency	(Hz) :	50	47	63

PHOTOMETRIC DATA:

		RATED	MIN.	MAX.
UVA Irradiance @ 1m	(mW/m²) :	50	38	63
Peak Wavelength	(nm) :	370	365	375
Dominant Wavelength	(nm) :	465	-	-
Luminous Flux	(lm) :	10	-	20
Chromaticity Co-ordinates	(x,y) :	0.150 , 0.025	6 SDCM	

LIFE DATA:

		RATED	MIN.	MAX.
Average Life (L ₅₀)	(h) :	12,000		
Abrupt Failures @ Rated Life	(%) :			10
Switching Cycles	(#) :		100,000	

OPERATING CONDITIONS:

		RATED	MIN	MAX
Ta Ambient temperature range	(°C) :	25	-40	45
Tp Point (measured VBD)	(°C) :	50	-	70
Starting Time	(s) :	-	-	<0.5
Warm-up Time to >95% Flux	(s) :	-	-	<1.0
Burning Position	:		Universal	
External Control Gear type	:		None	

APPLICATION: Ultraviolet source to replace fluorescent blacklight lamps. Suitable for indoor use only. Suitable for operation directly on 230V mains supply. Not dimmable. Complies with IEC62560, IEC62612, IEC62471, IEC61547, IEC61000, EN55015, EN62493.

Issued by : TIENEN

Revision date : 16-III-2021

DATA SHEET

Specification No. : 70-T-0086301/D

Page : 1 of 2

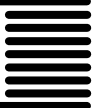

PHOTOMETRIC GRAPHICS:

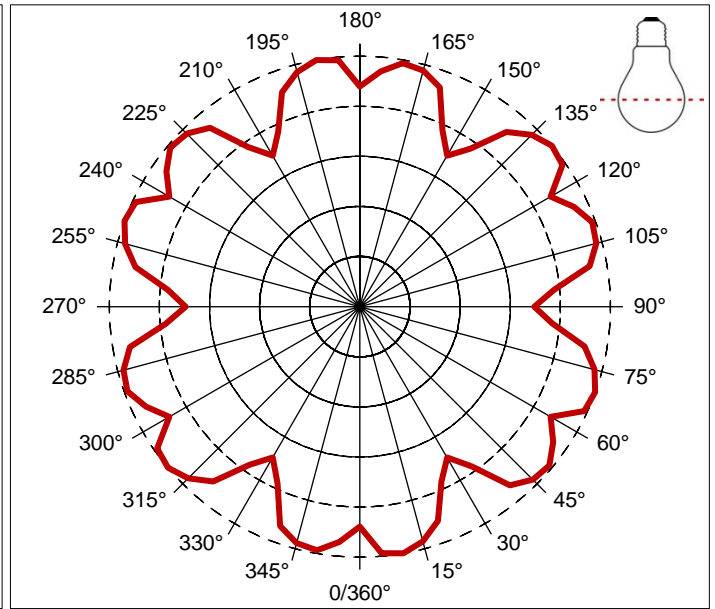
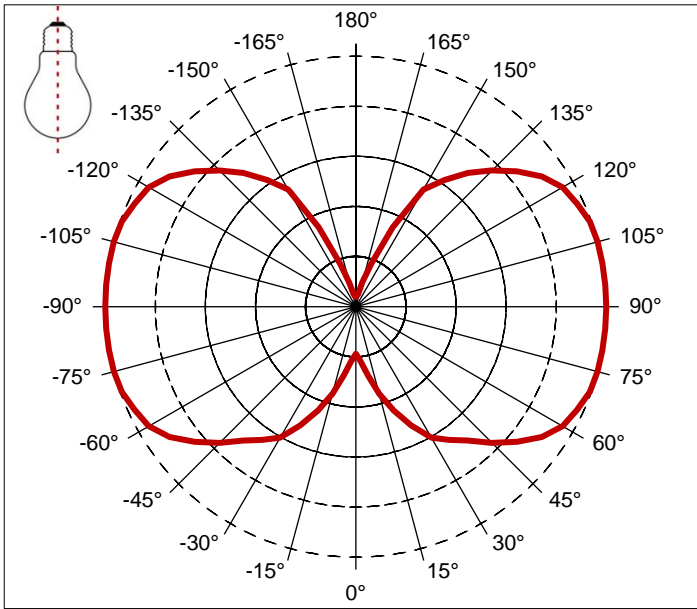

SPECTRAL GRAPHICS:

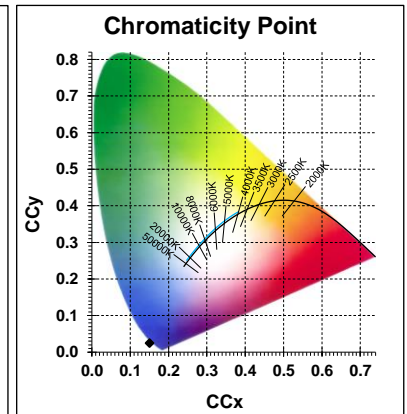
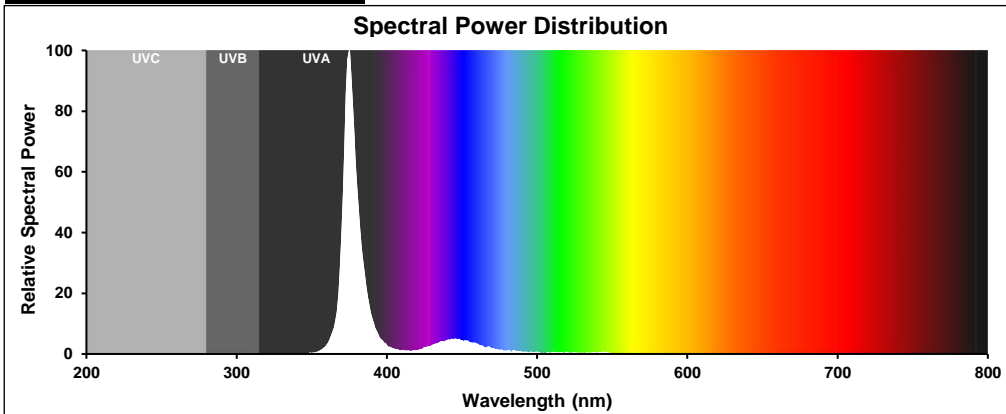

PERFORMANCE GRAPHICS: (Under Consideration)

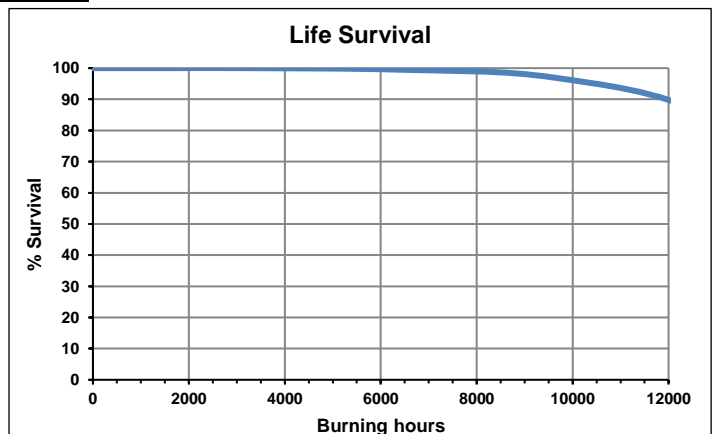
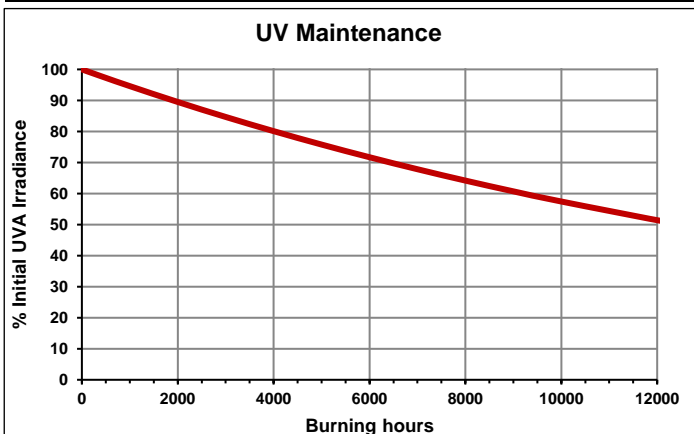

Issued by : TIENEN
Revision date : 16-III-2021

DATA SHEET

Specification No. : 70-T-0086301/D
Page : 2 of 2