

Funke- Dr. N. Gerber Labortechnik GmbH
D - 12105 Berlin, Ringstraße 42
Tel.: +49 - 30 - 702 006 - 0 Fax: +49 - 30 - 702 006 - 66
Email: kontakt@funke-gerber.de
www.funke-gerber.de

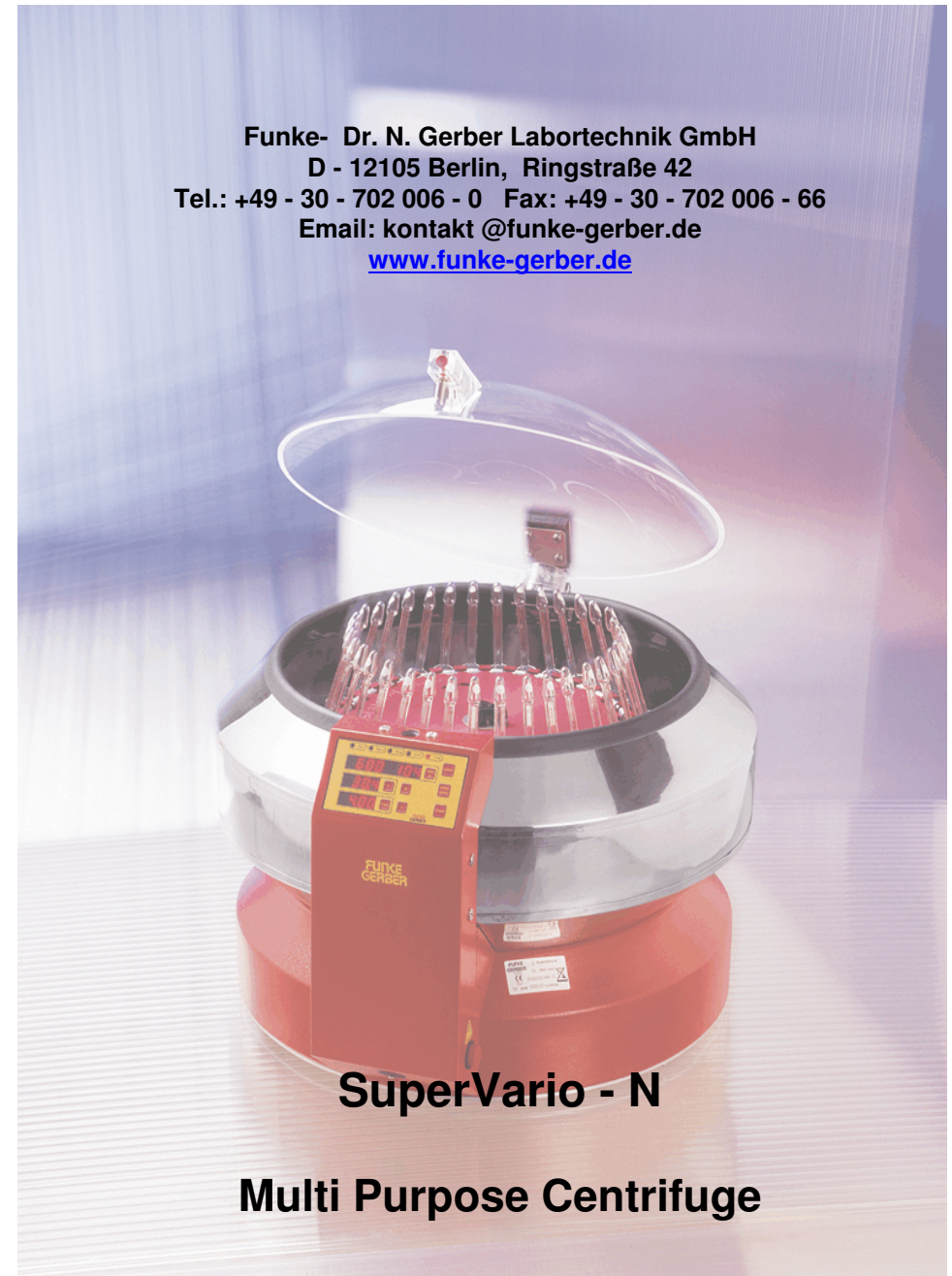

SuperVario - N

Multi Purpose Centrifuge

Manual: Contents

1	Assembling and starting	3
2	Using the centrifuge	3
2.1	Function of the keys	3
2.2	Operation	4
2.2.1	Setting to operation	4
2.2.2	Start of centrifuge	4
3	Display / Settings	5
3.1	Setting of temperature and time	5
3.2	Setting of mode	6
3.2.1	Setting of speed	6
3.2.2	Setting of temperature	6
3.2.3	Setting of centrifugation time	7
4	Informations about using	7
5	Tabular summary on Relative Centrifugal Acceleration	9
6	Technical Data	10
7	Ordering data	10
8	Spare parts	12
	EC-Declaration of Conformity	13
App. 1:	Drawing: Main Control	14
App. 2:	Drawing: Motor-Control	15
App. 3:	Drawing: Electrical Connections	16

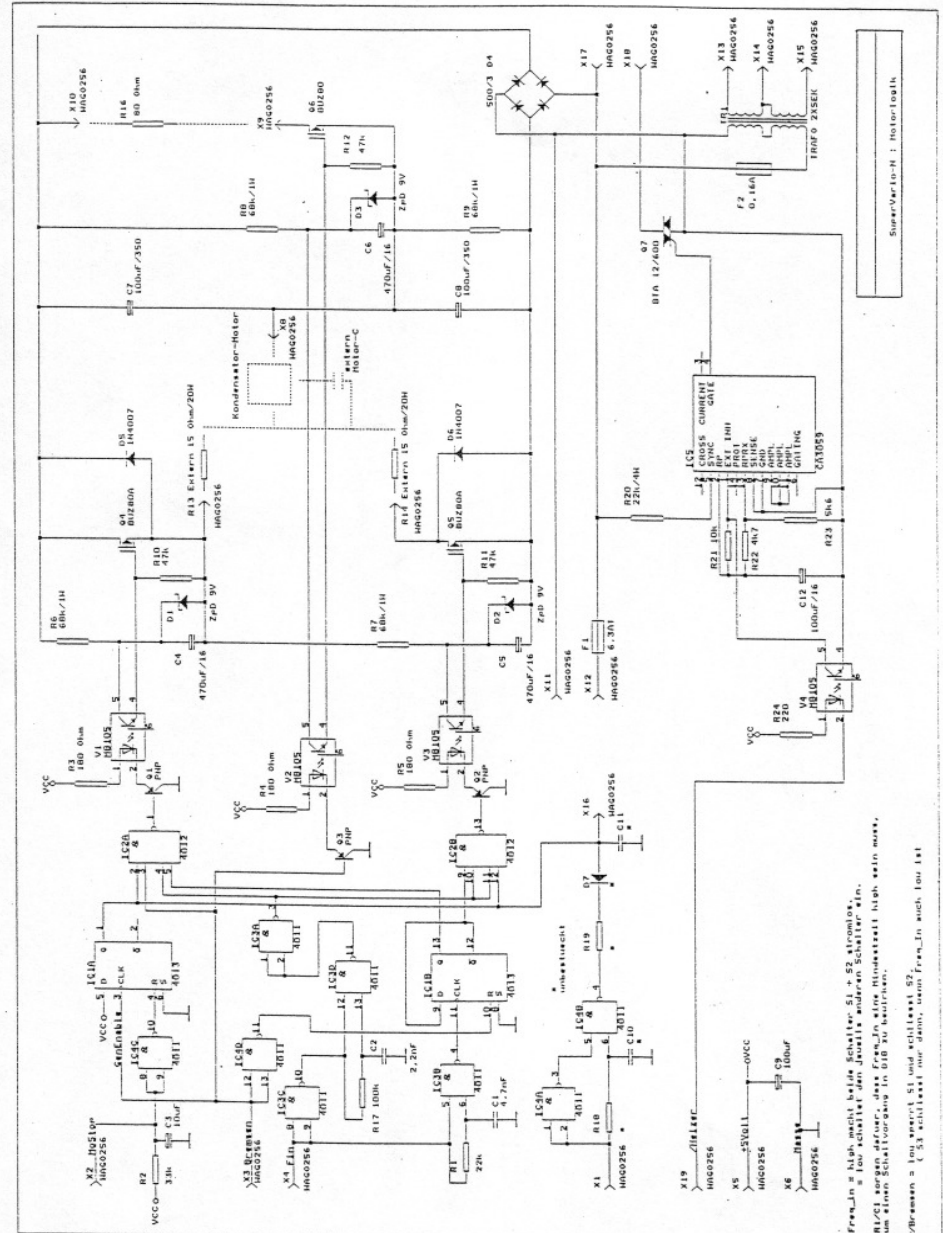

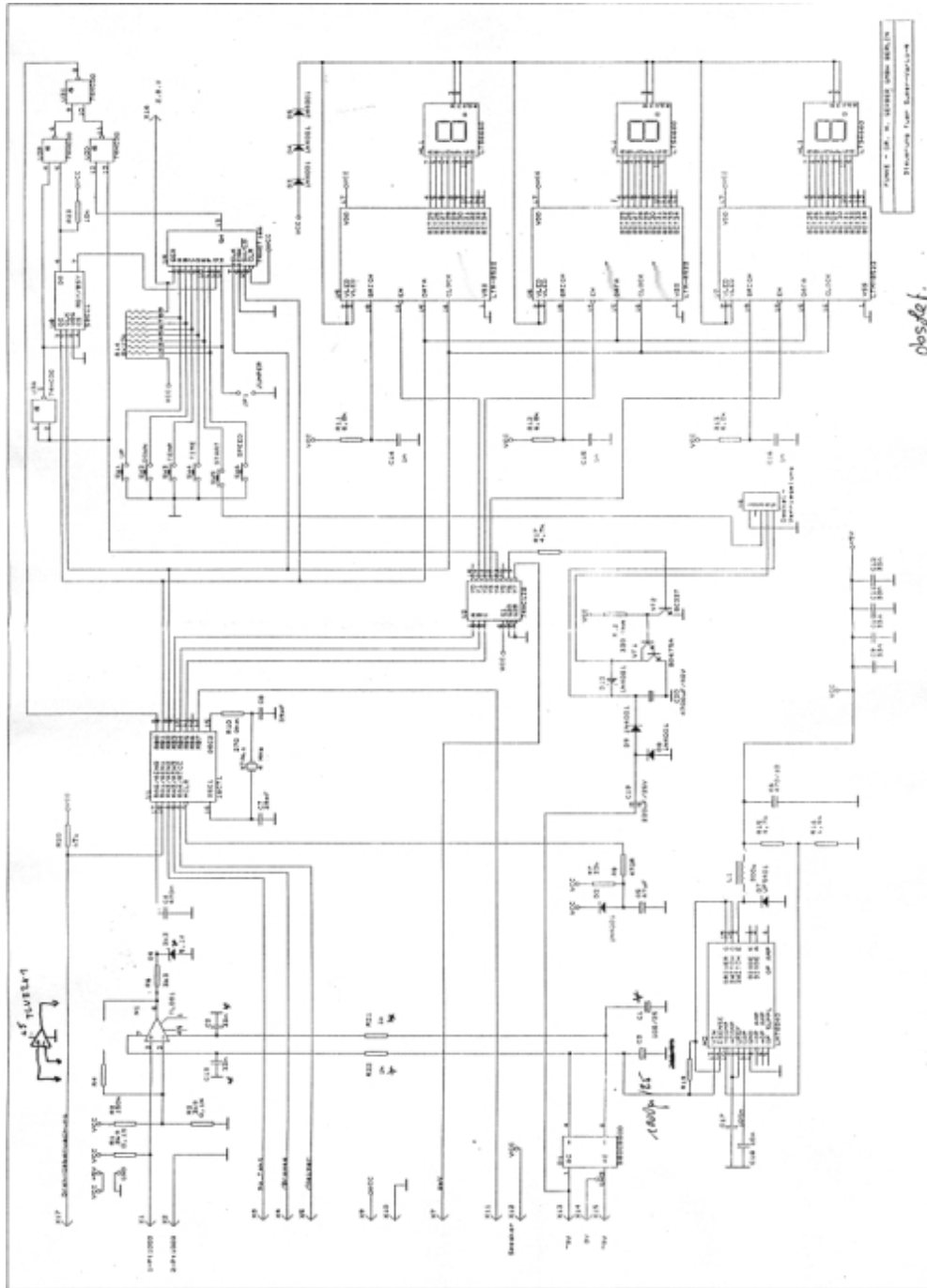

1 Assembling and starting

Put the centrifuge on a plain and horizontal place. The ambient space around the centrifuge should be at least 30 cm. Then plug the main cable into a wall socket capable to supply the centrifuge with 6 A / 230 V.

Caution: Use a safety type wall socket with a well grounded safety contact! Do not use any other socket type!

The main switch is located on the right side of the front panel. Switch the centrifuge on by pressing it. After approx. 2 or 3 sec. the display is lighting. Now press key "STOP/OPEN" and the lid locking is set free.

Then switch off the centrifuge by pressing again the main switch. Open the lid and remove all packing material used for protecting the motor during transportation. Possible residues of adhesive tape have to be removed.



Put the desired head on the motor spindle and fasten it by the tommy screw and the washer. The tommy screw should be fastened strongly by hand (but without a tool).

2 Using the centrifuge

2.1 Functions of the keys

The following eight keys are:

	Setting of desired speed. (together with "+" or "-" button)
	Setting of desired temperature (together with "+" or "-" button)
	Setting of desired time (together with "+" or "-" button)
	Raising the value while setting a parameter
	Decreasing a value while setting a parameter.

	This button is for choosing a method. The chosen method will be shown by a glowing LED.
	Stop of centrifuge
	Start of centrifuge

2.2 Operation

2.2.1. Setting to operation

After having assembled and prepared the centrifuge according to point 1 of this manual the display is showing the desired speed (revolutions per minute), the actual temperature (in °C) and the desired centrifuging time by the active mode. Take care that the device is set up according to the desired analysis method, i.e. the values (as per point 3.2) are set properly.

2.2.2. Start of centrifuge

Attention: Recheck the right fastening of the tommy screw !
The test bottles have to be placed symmetrically to avoid unbalances. Afterwards the lid is closed and pressed down until an audible catching can be heard. Then press the key START and start centrifuging. In case the lid was erroneously closed and the centrifuge has not yet started it can be opened by pressing the key STOP/OPEN.
At the end of centrifuging time the centrifuge is braking and opening the lid locking. The braking time depends on the speed. It is between about 15 sec. (at 600 rpm) and 25 sec. (at 1100 rpm) Braking times are preset. The centrifuge switches off automatically in case it is out of balance and the free moveable motor is touching the housing.

Note: On account of safety reasons every switching off due to unbalance is followed by a braking. Same is done in case of a coarse knocking on the centrifuge. In order to stop the centrifuge by hand press the key STOP.

**FUNKE
GERBER**

Funke-Dr.N.Gerber Labortechnik GmbH
Ringstraße 42
12105 Berlin



EC Declaration of Conformity under the EC Machine Directive 98 / 37 / EC, Appendix II A

We declare that the machine referred to herein below, as put on the market, has been designed and manufactured to the fundamental safety and health standards as defined in the EC Machine Directive. This Declaration shall become null and void in the case of any modification made without our prior consent.

Designation of the machine: **SuperVario-N**
Maschinen type: Mult purpose centrifuge
Serial number: **3680 - _____**
Applicable EC Directives: EC Machine Directive as amended by 98 / 37 / EC
Low Voltage 2006 / 95 / EC
Electromagnetic Compatibility 2004 / 108 / EC

Berlin, this _____

Funke-Dr.N.Gerber Labortechnik GmbH

Dipl.-Ing. K. Schäfer, Managing Director

8 Spare parts

Art.No.	Designation
3680-010-Dok	Users manual and reference
3680-021	Centrifuge bowl, stainless steel
3680-022	Front part
3680-023	Main control
3680-024	Motor-control
3680-025	Motor GEFEG ES 9080-4AL-RL, completed
3680-031	Lid lock
3680-032	Hinge, complete
3680-121	Handle of lid
3680-191	Lid
3680-201	Washer for head fastening
3680-241	Threaded bolt for tripod hanging
3680-242	Formed part, rubber, for tripod hanging
3680-243	Metal washer for tripod hanging
3680-244	Rubber feet
3680-248	Tommy screw for fastening the head
3680-251	Cap for emergency opener
3680-254	PT100 temperature sensor
3680-257	Main switch
3680-258	Cap for main switch
3680-259	Motor capacitor 24 uF
3680-260	Clamp for motor capacitor
3680-261	Fuse 6,3 A delay action
3680-262	Fuse 160 mA medium delay action
3680-263	Foil key board

Note: The centrifuge can only be started with lid locked and in case it is not in the setting modus.

Attention: The centrifuge bowl is to be kept always clean. In case glasses were broken it should be cleaned immediately

3 Display / Settings

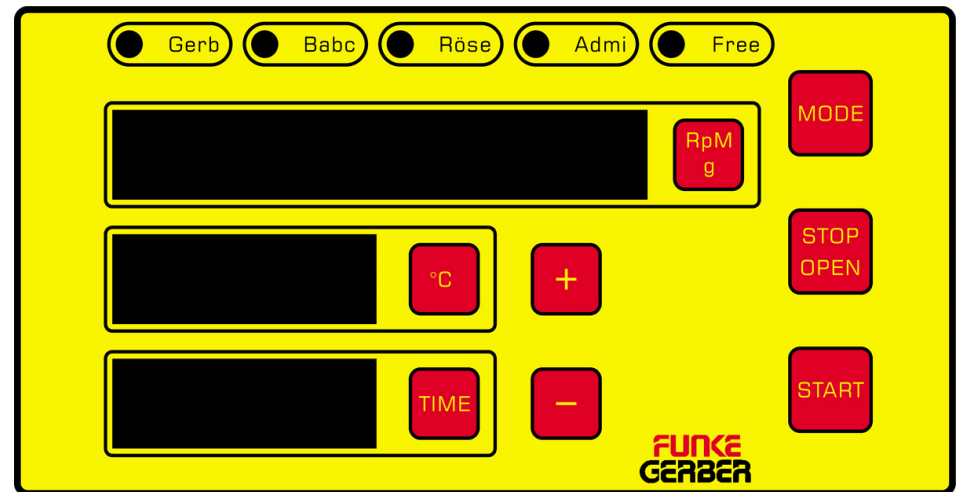

3.1 Setting of temperature and time

The temperature will be set in steps by 0,5°C as well as the timer, which will be set in steps by 1 minute. All these settings are stored and remained stored without connection to the supply voltage.

During the running of the centrifuge it is not possible to change the settings.

3.2 Selecting the mode

Five different modes are selected by pushing the button "mode". According to the selection the revolutions per minute and temperatures are predefined automatically and are displayed. The speed and the

temperatures are unchangeable preset and cannot be changed for the following modes:

- “Gerb” = Gerber-method (Fat determination)
- “Bab” = Babcock-method (Fat determination)
- “Röse” = Röse-Gottlieb (Fat determination, reference-method; only permitted under following the respective national safety regulations.)
- “Admi” = Solubility of milk powder (acc. ADPI)

Under these modes only the duration of centrifugation can be changed.

- “Free” = Free Mode: In this mode all parameters can be set freely.:

3.3 Setting of speed

At first the button "RpM/g" has to be pressed. By pressing the button "+" or "-" together with the button "RpM/g" the desired speed can be adjusted. The range is from 600 to 1130 revolutions/minute in steps of 10 revolutions/minute.

3.4 Setting the temperature



At first has to be pushed to the button " C° ". Now, the already set temperature will be displayed. By pressing the button "+" or "-" together with the button "°C" the desired temperature can be adjusted. As soon as let off the buttons, the setting is stored and the display is showing again the actual temperature.

Note: During breaks (stand by mode / the centrifuge is not running) the temperature will be reduced around 10° C to avoid local overheat.

<p>3686</p>	<p>Head B Protective drum for 8 Mojonniertubes Material: Aluminium</p>	
<p>3687</p>	<p>Head C up to 6 solubility index tubes Material: Aluminium</p>	
<p>3631</p>	<p>Bucket for butyrometer of aluminium alloy Material: Aluminium</p>	
<p>3632</p>	<p>Bucket for Babcock bottles Stainless steel, V2A</p>	
<p>3633</p>	<p>Bucket for solubility index tube Stainless steel, V2A</p>	

Voltage	230 V A/C 50..60 Hz
Total powerconsumption	1.200 W
Powerconsumption motor	200 W
Powerconsumption heating	1.000 W
Weight (empty)	26 kg
Total height with lid	460 mm
Charging height (without lid)	370 mm
Diameter	590 mm
Height of panel(center)	360 mm
Speed	600..1130 rpm
max. temperature allowed	up to 68 °C
Temperature range	up to 68 °C
Centrifuging time	1 - 99 minutes
Unbalance activation	at a deviation of about 3-5 mm
Lid lock	built-in, mechanical lock delocking electrically
Disconnection of heating	below 1000 rpm
heat reduction on standby	10 °C

7 Ordering data

Art.-Nr.	Description	Picture
3680	Centrifuge SuperVario-N	
3685	Head A up to 36 butyrometers up to 18 Babcockbottles Material: Aluminium	

3.5 Setting of Centrifuging time

At first the button "TIME" has to be pressed. By pressing the button "+" or "-" together with the button "TIME" the desired speed can be adjusted. As soon as let off the buttons, the setting is stored.

Note: The time, which has been set, is the time from the very beginning till the end, including the time for acceleration (approx. 50 seconds) and the time for braking (20 seconds). Please take into account.

4 Information about using

Following some questions and answers that may occur.:

- How to charge head A?

Head A has 36 places. When using butyrometers of measuring method (1 stopper) all 36 positions can take a butyrometer. When centrifuging butyrometers of weighing method (2 stoppers) or Babcock bottles max. 18 positions can be used (every second one).

- What is happening when centrifuge starts and brakes?

The centrifuge need approx. 30 sec. for reaching 600 rpm and up to 70 sec. for reaching 1100 rpm with head A fully loaded. Due to construction a higher speed than the set one is not possible - neither when starting nor when centrifuging.

The brake is electrically activated and therefore smooth and nearly shock-free.

- How is the heating acting?

The heating is only active at a desired speed of 1000 rpm and above regardless whether centrifuge stops or is running. At the beginning at least 30 minutes are necessary for reaching 65 °C.

Note: During standby the centrifuge reduces the heating to avoid local overheat. The amount of reduction is 10 °C.

- How to open centrifuge at failure of current supply?

On the bottom side of the front part there is a black cap. In case of emergency loosen this cap by a sturdy screw driver and pull the cord fastened inside.

Attention! This should be done only in case of emergency. The cap is mostly destroyed after it and has to be exchanged. Using the centrifuge with cord lying open is forbidden.

- Why is the last decimal point of temperature lighting sometimes?

This lighting point indicates that heating is actually activated.

- Centrifuge does not correspond to key START. What may be the reason?

The lid locking is not wholly caught. Press again. The catching can be heard. When the centrifuge is braking no key can be used. This is not affectable.

- After start centrifuge brakes immediately. What may be the reason?

The centrifuge is not placed horizontally or is unbalanced. This can be tested by holding the tommy screw and moving the freely mounted motor slightly into all directions. There should be a space of 3 to 5 mm.

- Are there fuses and are they exchangeable?

Yes, the centrifuge has one (from 2/95 two) main fuse (6,3 ampere, delay action) and a fuse for the electronics (0,16 ampere, medium delay action). Both fuses are mounted on the print board in the lower part of the centrifuge.

In order to exchange the fuses the centrifuge is to be disconnected from the mains and to be put gently on its side. Then the base plate can be screwed off (6 screws). Now the fuses are accessible.

- Immediately after switching on the centrifuge displays "br.." and starts to brake. Why this?

The centrifuge was previously interrupted while centrifuging or braking - maybe by failure of power. On next startup it performs at first a noninterruptable brake (for security). This takes about 30 seconds. After

that the lid can be opened.

5 Tabular summary on Relative Centrifugal Acceleration

Speed	Head A, r=26 cm RCA [g]	Head B, r=38 cm RCA [g]	Head C, r=38 cm RCA [g]
600	105	77	77
620	112	82	82
640	119	87	87
660	127	93	93
680	135	98	98
700	143	104	104
720	151		110
740	159		117
760	168		123
780	177		129
800	186		136
820	196		143
840	205		150
860	215		157
880	226		165
900	236		172
920	246		180
940	257		
960	268		
980	280		
1000	291		
1020	303		
1040	315		
1060	327		
1080	340		
1100	352		
1120	365		

6 Technical data